

UNIVERSAL LIGHTPROBE™ S2 ULTRA-HIGH SENSITIVITY SENSOR

Universal LightProbe S2 Ultra-High Sensitivity Sensors are designed for the test of very dim LEDs, as low as 0.01 mcd minimum, and including very low light-level LED-illuminated action-indicator switches, controls and status indicators for night/dark viewing in automobile interiors. Recommend the use of wide-aperture stainless-steel encased Fiber-optic Probes with contacting tips.



Part Number: ULP-S2 UHS

ON/OFF RESPONSE

- Tests the ON/OFF status of any color LED
- Provides a Logic "1" output of 5 volts only if the LED is ON and a Logic "0" if the LED is OFF
- "Color-blind" sensor will check the ON/OFF status of any color LED
- Provides the simplest and fastest 1-bit digital interface to automatic test equipment, requiring no further PASS/FAIL processing by the ATE software

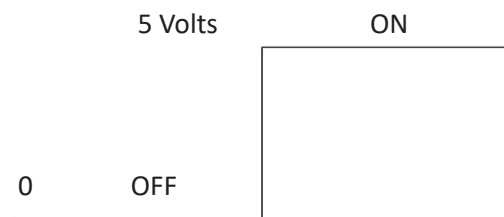

INTENSITY RESPONSE

- S2 Ultra-High Sensitivity Sensors do not provide an intensity output
- S2 Ultra-High Sensitivity Sensors respond to a wide dynamic range of LED intensity without adjustment
- Will test surface-mount LEDs of 0.01 mcd minimum
- Will test finished product LED displays, e.g. RJ45 T-1 / 3mm LEDs of 0.15 mcd minimum

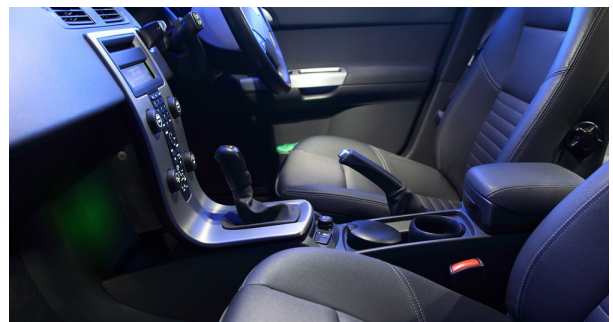

UNIVERSAL LIGHTPROBE™ ULTRA-HIGH SENSITIVITY SENSOR

All Universal LightProbe Sensors share the same form, and are pre-programmed to suit specific LED test requirements. The small size and non-conductive housing is specifically designed to accommodate today's high-density test fixtures.

ULTRA HIGH-SENSITIVITY (UHS) SENSOR CHARACTERISTICS:

Operating temperature range: 0°C to 70°C

Power consumption: Operates between +5 and 28 volts D.C., at 6mA max. Less than 4.75 volts is not recommended

Voltage protection: Withstands up to +40 volts, & reverse polarity to -18 volts

Signal Output Loads: 20 mA max. Non-inductive.

Output Pins: 3 gold-plated standard wire-wrap pins (0.025 in. sq.)

Sensor Size: 0.560 in. dia x 1.38 in. long.

Typical response times: <190mS

Fiber-Optic Probes: Wide-Aperture Fiber-Optic Probe recommended

Designed for the test of very dim LEDs, as low as 0.01 mcd minimum

ULTRA HIGH-SENSITIVITY (UHS) SENSORS: Three standard wire-wrap pins

G - Ground: common for digital output and power input

S - Status of LED: ON = Logic '1' (5v); OFF = Logic 0 (0v)

P - DC Power Input: Between +5 and 28 volts; less than 4.75 volts is not recommended

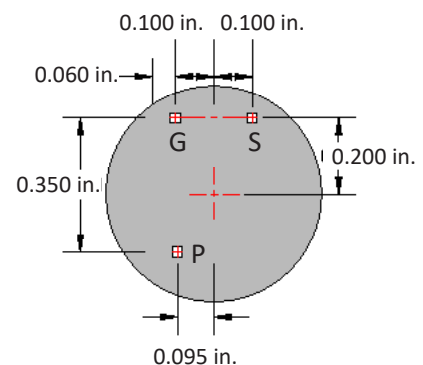
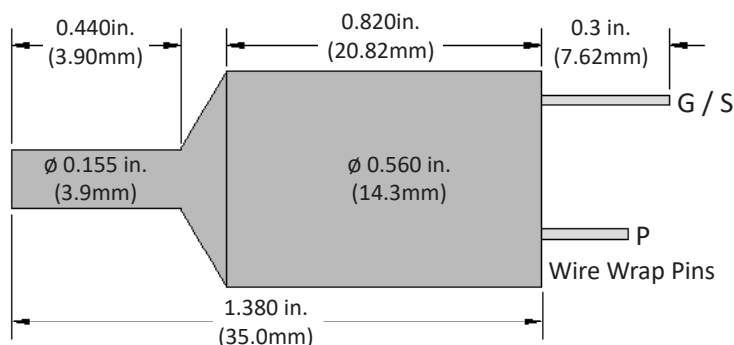

PO Box 751 • South Freeport, ME 04078 USA | Phone (207) 865-9181 • Fax (207) 510-8039

www.optomisticproducts.com

info@optomisticproducts.com